

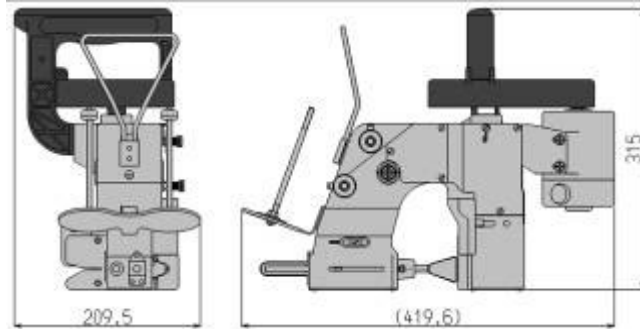

1999年10月18日、藤岡ニューロン工業株式会社
ミシン事業部はISO9001【国際品質保証管理規格】
認証を取得しました。

NP-3II

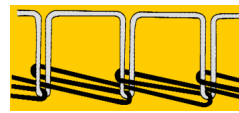

■ SPECIFICATIONS

Model	NP-3II
Capacity (r.p.m)	1,650±100
Stitch Range (mm)	8.5 (fixed)
Seam	Double thread chain stitch
Thread Cutting	Automatic
Drive Motor (w)	90,1Ph (specity voltage)
Net Weight (kg)	6.0 (14lbs) with thread

NP-7A

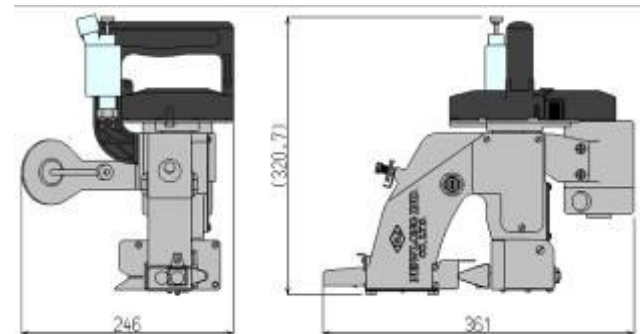

■ SPECIFICATIONS

Model	NP-7A
Capacity (r.p.m)	1,700 ~ 1,900
Stitch Range (mm)	8.5 (fixed)
Seam	Single Thread Chain Stitch
Thread Cutting	Automatic
Drive Motor (w)	90,1Ph (specity voltage)
Net Weight (kg)	5 (13lbs) with thread
Gross Weight (kg)	Approx. 8.7



NEWLONG INDUSTRIAL CO., LTD.

8-14,SHIRATORI,4-CHOME,KATSUSHIKA-KU,TOKYO,125-0063,JAPAN

TOKYO HEAD OFFICE
MECHANICAL DESIGN ENGINEERING DEPT.

TEL:81-3-3603-2284 FAX:81-3-3603-2253
TEL:81-3-3603-2252 FAX:81-3-3602-2694

U R L <http://N L www.com/>
E -mail info@nlwww.com

PORTABLE BAG CLOSER

NP-3II NP-7A



NP-3II
Recommended for bags of all materials, like jute, paper, cotton, PP, etc.
Double thread chain stitch ensures tightest closure.



NP-7A
For minimum cost closing of all kinds of bags. Single thread chain stitch, with simple mechanism for easier maintenance. New type NP-7A is provided with a plastic handle and an auto-lubrication.