



Application & Installation Recommendations for Single and Multi-idler belt weighers

COPYRIGHT 2008

No part of this manual may be reproduced without the prior written consent of Accuweigh Pty. Ltd.

ACCUWEIGH PTY LTD

www.accuweigh.com.au

This manual is ACM002GB Revision 1

Revisions

Rev	Date	By	Chk	App	Description
0	07-03-07	DFH	JFH	MAA	FIRST ISSUE
1	13-03-08	DFH	JFH	MAA	CORRECTED ERRORS

Please read and observe all of the recommendations in this manual. If in doubt, or if the application is a legal for trade application, have the installation reviewed by our application engineers. To achieve and maintain the specified accuracy, belt weighers must be installed in accordance with these recommendations and serviced, maintained and calibrated in accordance with the manuals.

The frequency of calibration varies depending on the application and site conditions, if discrepancies are noticed in the operating performance or during calibration of the weigher, service and calibration may be required more frequently. As guideline, we recommend calibration twice a year in line with the legal for trade requirements.

Specified accuracy is based on the results of material testing (also known as live load test) in which material is run over the belt weigher and accurately collected. The quality material must be the greater of 10% of the maximum feed rate in one hour or one complete revolution of the belt. In legal for trade applications the accuracy is specified in accordance with the National Measurement Institute (NMI) or OIML document R50.

Consider providing the means (by-pass chutes, weigh bins) for material testing in new plant design, especially in legal for trade applications.

The accuracy of a belt weigher installed without a speed sensor will vary with the belt speed.

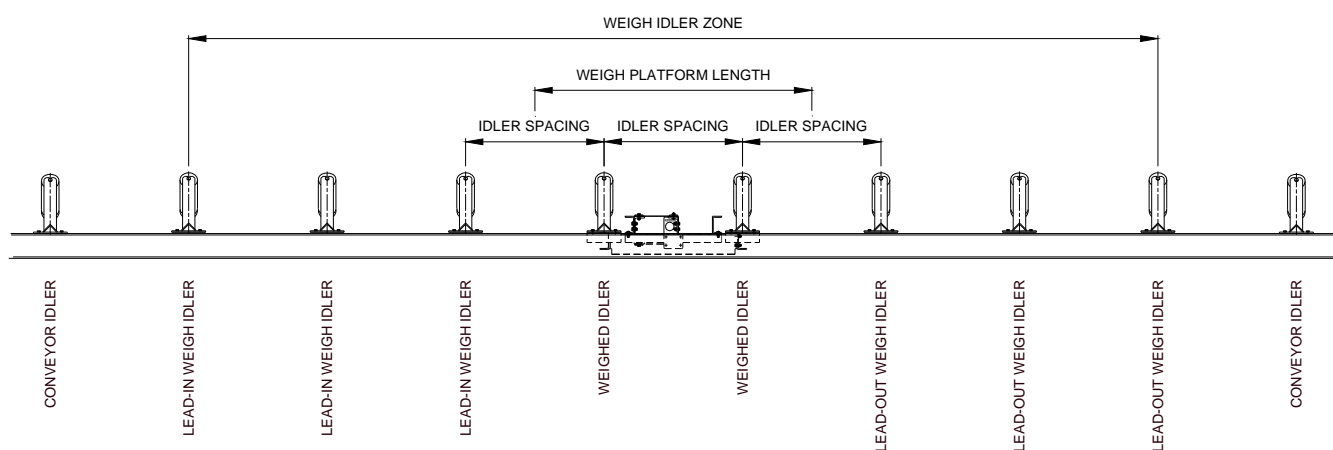

Weigh idler zone

The section of the conveyor fitted with weigh quality (balanced and machined) idlers. The weigh idler zone includes the idlers mounted on the belt weigher (weighed idlers) and the weigh idlers preceding (lead-in weigh idlers) and following (lead-out idler) the weighed idlers.

Weigh platform length

The length of the material or belt load on the conveyor the belt scale is measuring. It can be calculated as half the load from between both the lead-in and lead-out idler plus, in the case of multi-idler weigher, the load between the weigh idlers.

Location of the weigher in the conveyor

The belt must sit flat on all the idler rollers in the weigh idler zone under all operating, site and climatic conditions.

Belt tension greatly affects the accuracy of the belt weigher; the belt tension is lower near the tail of the conveyor and a maximum at the head of the conveyor.

Where possible, try to install the weigher as close to the tail as possible.

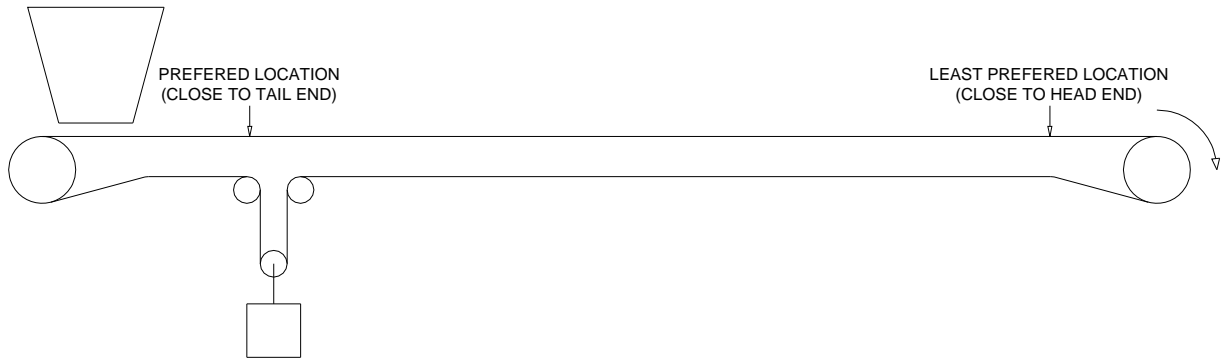

Mounting belt weighers in inclined conveyors or inclined sections of conveyors is permitted, however ensure that there is no movement of the material relative to the belt at all loading conditions.

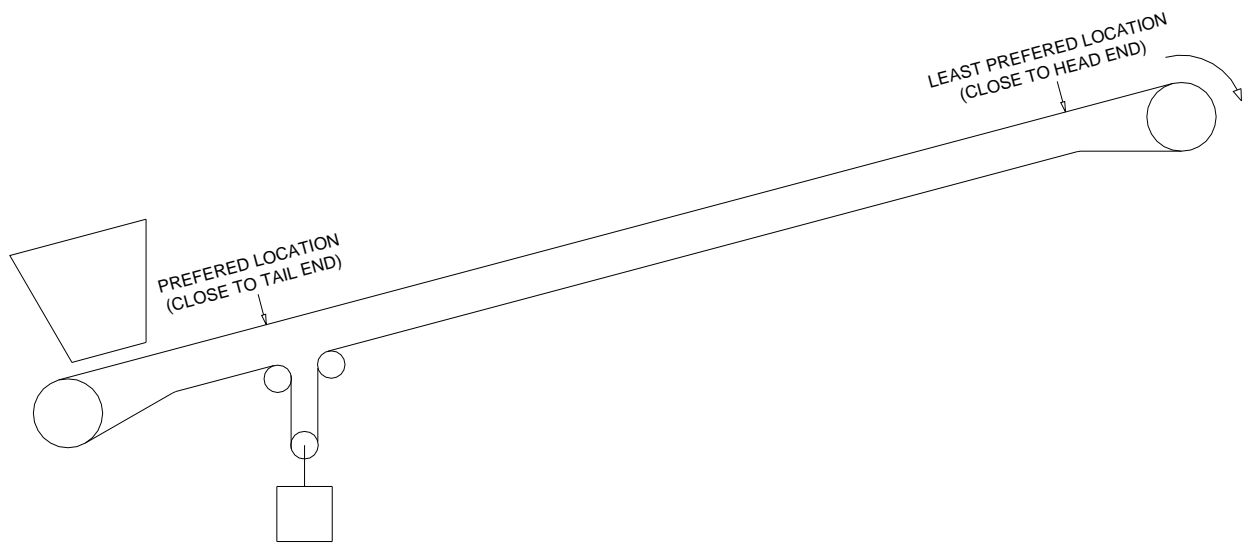

The weigher must not be mounted in the curve of a conveyor. The weigher must be at least 12 idler spaces from the end of a concave curve and 6 idler spaces from a convex curve.

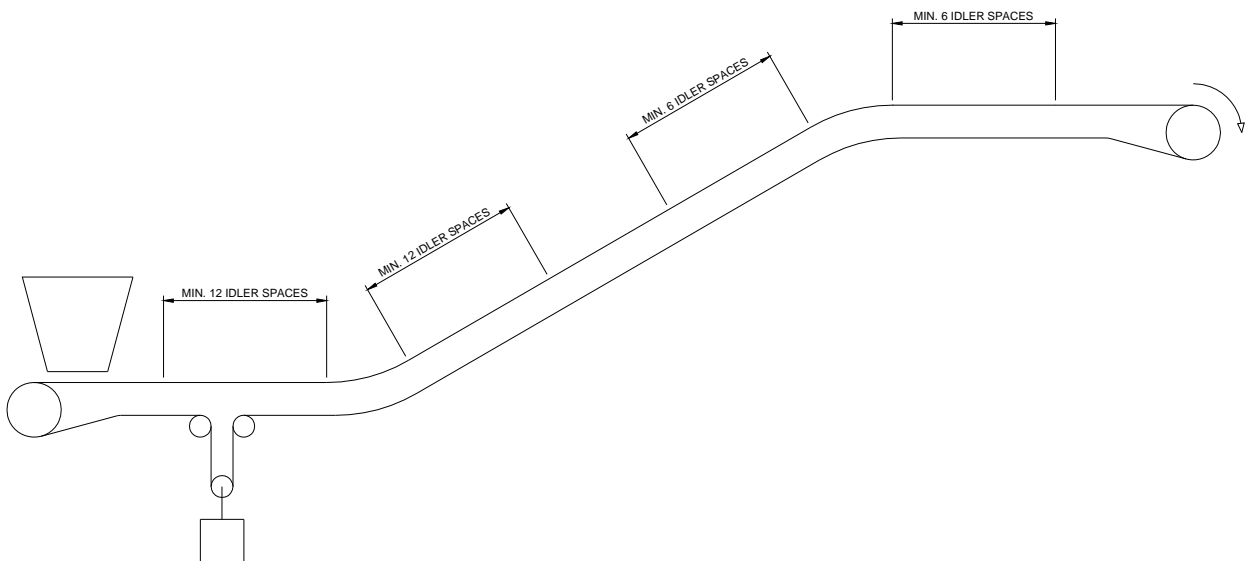

Position the weigher in the conveyor away from hoppers, chutes and transfer/transition points so that there is no movement of the material relative to the belt at all loading conditions.

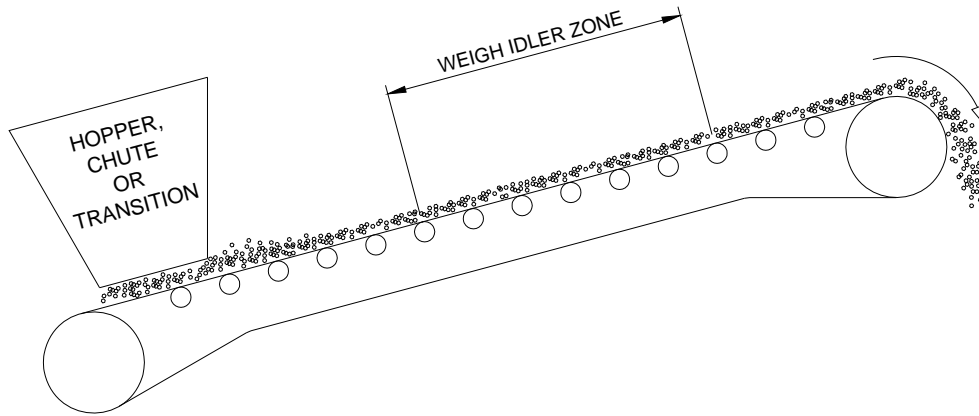

To facilitate routine weigh idler alignment and maintenance, ensure the weigh idler zone is at least one idler spacing clear of impact idlers and material (or Champion) skirts.

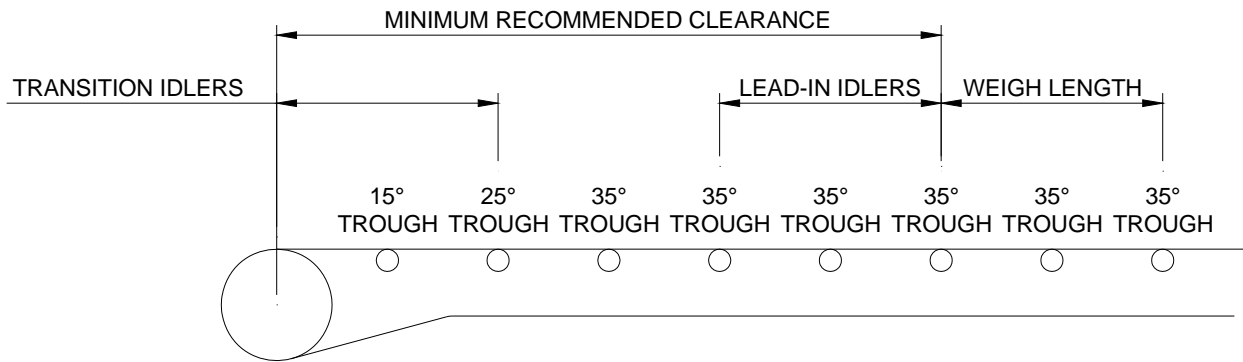

At any pulley with transition idlers, ensure the weigh length is a minimum recommended clearance of the greater of:

- 2.5 x the transition length
- Transition idler length + 1 conveyor roller + 3 lead-in/out rollers from the transition

Requirements for the idlers

Off-set conveyor rollers are not ideal for weighing applications and should only be used for low accuracy (>5%) or control applications.

The weighed idlers frames should be arranged to be a minimum of 15mm clear of the stringers. The existing idler frames can be cut to clear the stringers (with the feet re-welded to suit reduced weigher idler mounting, inside the conveyor stringers) or special weigher mounted idler frames can be ordered to suit the mounting holes on the weigher and clear the stringers.

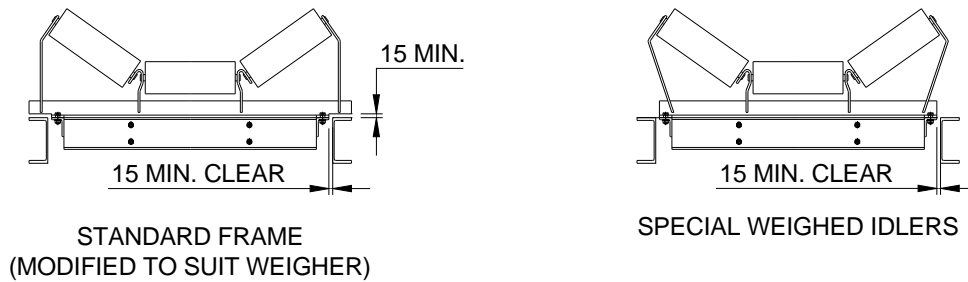

It is recommended that both the weigh rollers mounted on the belt weigher, the lead-in and lead-out rollers be balanced and machined. Our recommendation is that the roller be balanced to 0.014Nm and roller shell machined to 0.019mm total indicator run-out (T.I.R). Roller shafts should be fitted with an alignment locking screw both ends of the shaft to facilitate alignment.

We recommend that three lead-in and three lead-out idler frames be fitted with weigh quality rollers, however, when the belt speed is two meters per second or less, two frames can be used without adversely affecting accuracy. Please note that two lead-in/out idlers are more difficult to align accurately.

Weigh idlers within the weigh idler zone must be raised by 3-10mm and in alignment within 0.2mm tolerance.

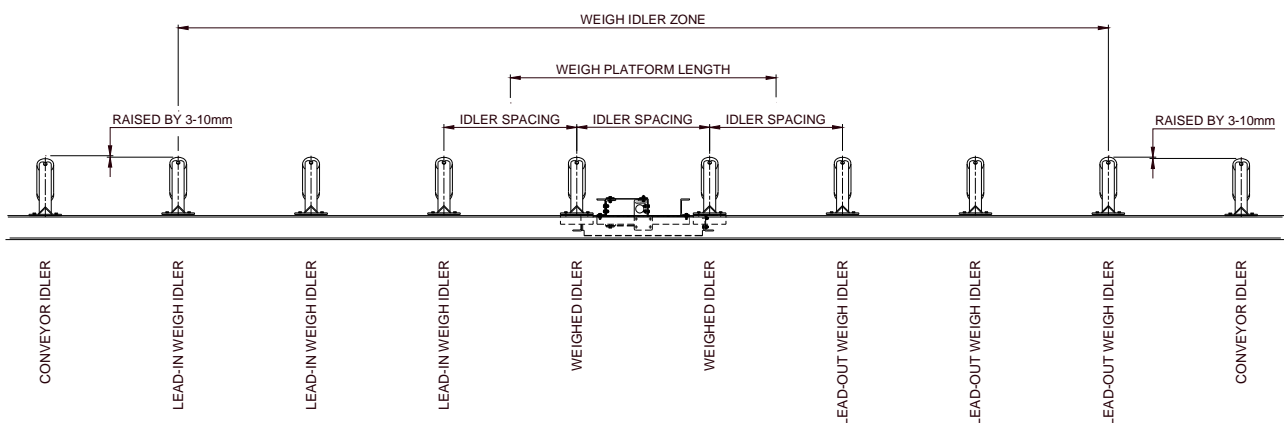

To ensure alignment, weighers should be aligned using 6 alignment wires on installation and as part of the routine calibration procedure.

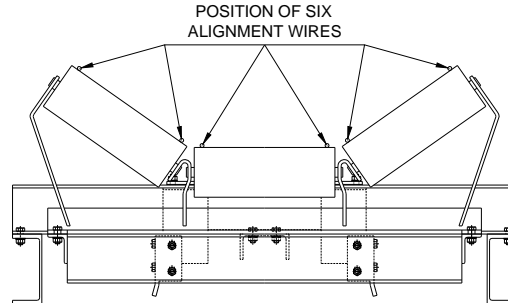

Pre-requisites for the conveyor

The conveyor should be fitted with a gravity take-up device. If a fixed winch type take is used, as the belt tension changes either from normal operation or from take-up is adjustment the weigher will require re-calibration.

Ensure the belt is kept free from material build up. Belt scrapers, side or troughed belt trainers are not to be installed in weigh idler zone. Wind guards are not to be used in the weigh idler zone, if high wind is expected install a cover mounted to the conveyor.

Conveyors that move (mobile, stacking or telescopic) conveyors are never ideal for accurate weighing the belt weigher will require re-calibration whenever the conveyor is moved.

Conveyor stringers must be continuous members (welded, not bolted) in the weigh idler zone. Stringers, supporting structure and foundation must be selected to ensure the idler alignment is maintained under all operating, site and climatic conditions.

Belt Weigher Application Datasheet

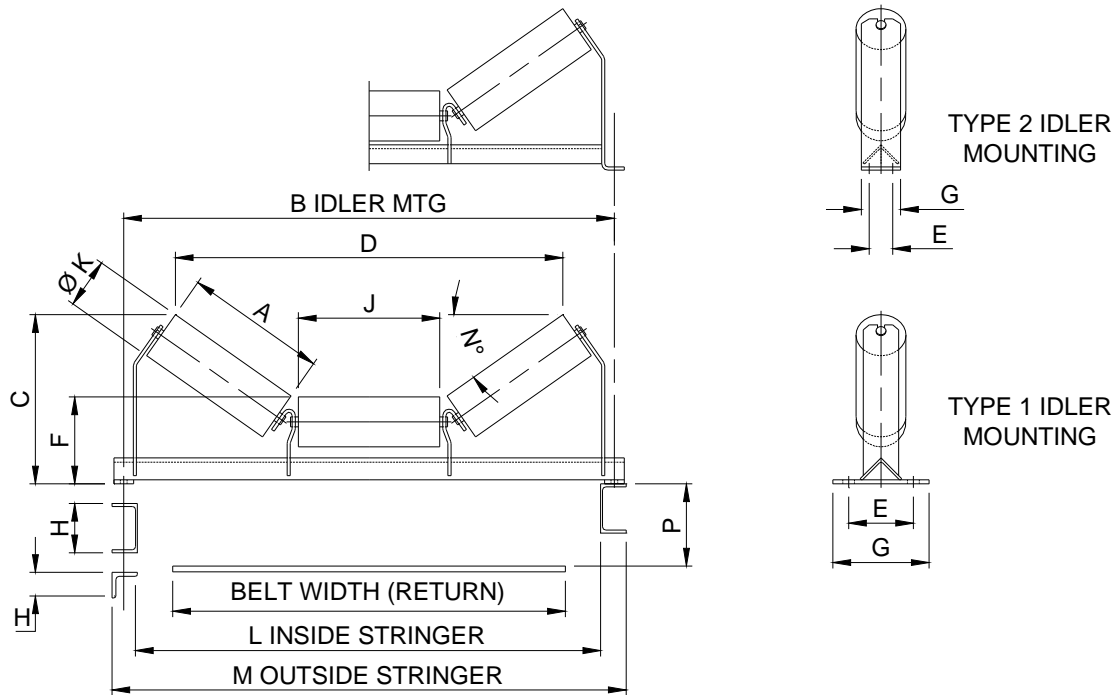

Application Data				Dimensional Data		
Flow rate max.		tph	A – Side roller face		mm	
Flow rate min.		tph	B – Idler mounting ctrs.		mm	
Required accuracy		%	C – Idler trough height		mm	
Material			D – Idler trough width		mm	
Bulk density		kg/m	E – Mounting ctrs.		mm	
Belt width		mm	F – Rolling height		mm	
Belt speed		m/s	G – Mtg. length		mm	
Belt Tension at weigher		kN	H – Stringer height		mm	
Idler spacing		mm	J – Ctr. Roll width		mm	
Required test weights (% of belt loading)		Manual	K – Idler roll dia.		mm	
		Lever	L – Inside stringer		mm	
		None	M – Outside stringer		mm	
Weigh idlers required ?	<input type="checkbox"/> Yes	<input type="checkbox"/> No	N – Troughing angle		°	
Idler make & model			Idler bearing No.			



ACCUWEIGH

ACCUWEIGH PTY LTD

www.accuweigh.com.au

