

SHIPPING CONTAINER WEIGHER

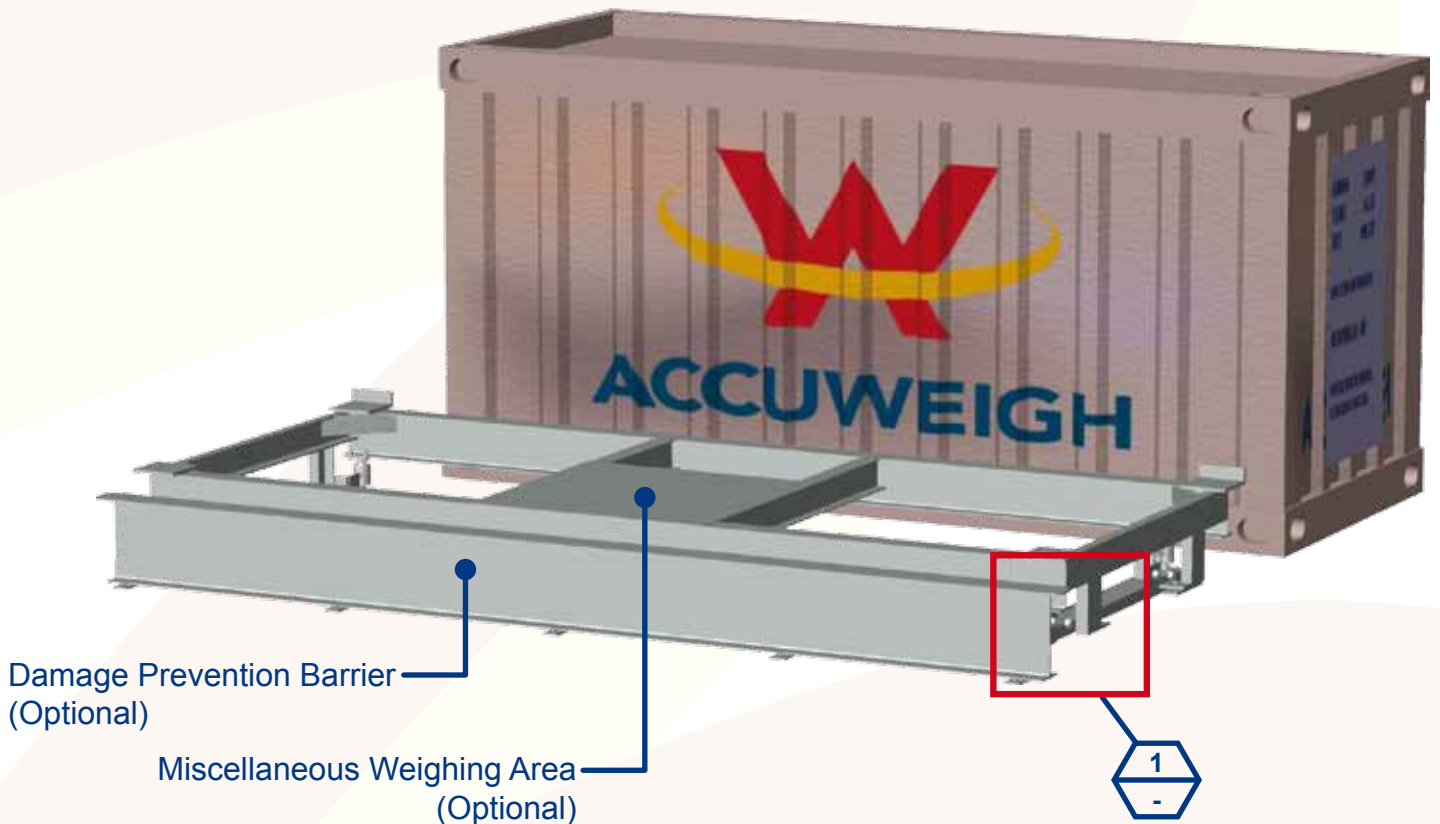

HIGHLIGHTS

- Trade-Approvable!
- 40t x 0.02t Capacity Standard
- Hot-Dipped Galvanised Finish
- Designed for Standard ISO 20ft x 8ft Shipping Containers
- 4 x 30t Capacity Weighbridge-Style Loadcells
- Adjustable Transverse and Longitudinal Restraints to Limit Movement
- Transport Locking Bolts to Enable Easy Weigher Relocation
- Choice of Digital Weight Indicator

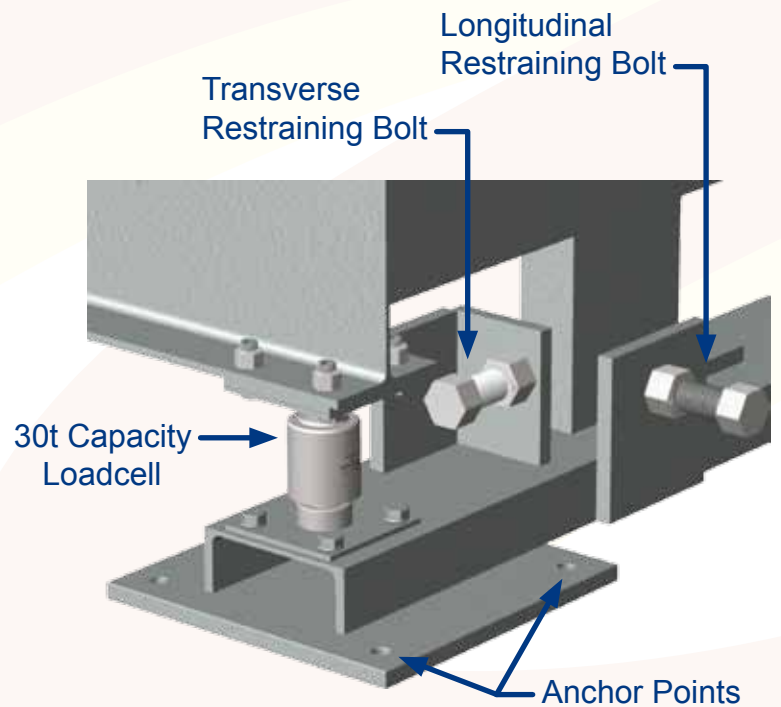

DETAIL



DESCRIPTION

Shipping Container Scales are normally used for attaining accurate weights of loaded shipping containers for freight purposes. Accuweigh's Shipping Container Scales feature an extra heavy-duty construction to resist heavy knocks and bumps expected in this very demanding weighing application where large forklifts are usually used for manoeuvring the containers on and off the Shipping Container Scales.

The construction of Accuweigh's Shipping Container Scales is unmatched in the weighing industry with the heavy-duty loadcells fully protected against both overloading and from side forces. All loadcell cabling is run in protective conduit. For added versatility, Accuweigh's Shipping Container Scales can be optionally fitted with a heavy metal plate positioned across the main support beams to allow other items to be weighed as on a general purpose platform scale.

Optional fittings such as fork lift bumper stops are also available for added protection against accidental damage caused by external forces such as reversing trucks, etc. Four AccuCell heavy-duty industrial loadcells, each with a 30t capacity, are fitted to the Shipping Container Scales for an overall working capacity of 40t with full trade approval.

OPTIONS

- A Miscellaneous Weighing Area that can be used as a standard Platform Scale for weighing bulka-bags or general items. This feature allows the Shipping Container Weigher to be multifunctional.
- A Damage Prevention Barrier ensuring that Operators must lift the shipping container onto the top of the Weigher, and thus avoiding front-on collision to the Weigher.
- Locking mechanisms to lock the container on to the weigher.

DIMENSIONS

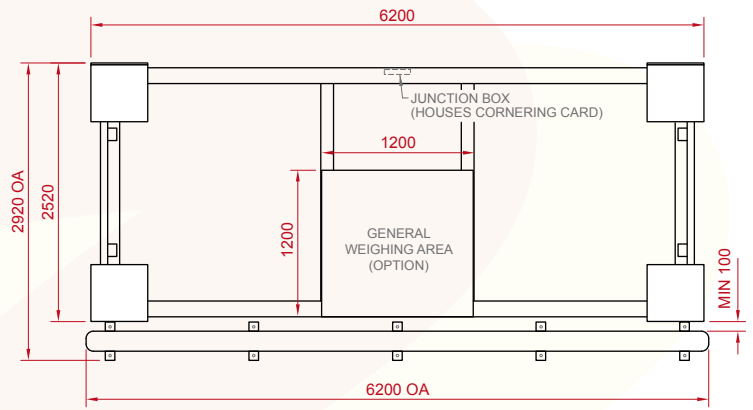

TOP VIEW



FRONT VIEW

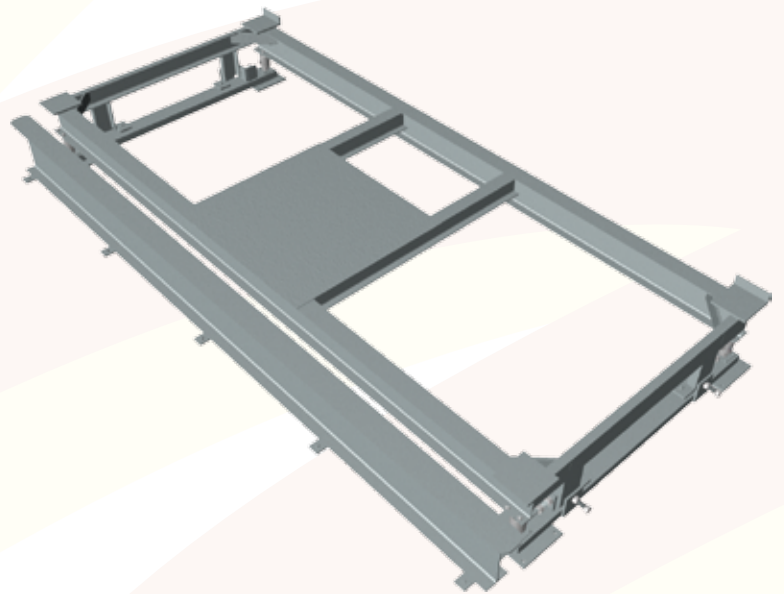

Accuweigh Pty Ltd

WESTERN AUSTRALIA (HEAD OFFICE):
PHONE: (08) 9259 5535

SOUTH AUSTRALIA OFFICE:
PHONE: (08) 8447 5011

NEW SOUTH WALES (SYDNEY) OFFICE:
PHONE: (02) 9728 4877



www.accuweigh.com.au

VICTORIA OFFICE:
PHONE: (03) 9548 5554

NEW SOUTH WALES (NEWCASTLE) OFFICE:
PHONE: (02) 4966 8900

QUEENSLAND OFFICE:
PHONE: (07) 3265 5520