

XS-A AND XT-A WASHDOWN PLATFORM SCALE

An ideal general purpose or check weighing scale for marine and food processing applications and for:

- Tough environments where there is possibility of knocks
- Where heavy wash down of the base is needed
- Check weighing and general purpose weighing



HIGHLIGHTS

- 304 Stainless Steel Construction Throughout
- 6mm Robust Frame
- Overload Protection Stops
- 1.2mm Thick Pan
- Overload Recording Increments Every Time the Scale is Overloaded
- Clear Open Frame is Easy to Keep Clean
- Removable, Low-Sided Pan to Deflect Splatter
- Sturdy Pan Construction for No Warping
- 2-Axis Rotating Head for Best Operator Viewing Angle

XS-A SERIES BASES

- IP-67 Stainless Steel Loadcell
- 310mm x 310mm Pan
- X320 or R420 Indicator

XT-A SERIES BASES

- IP-68 and IP-69K Stainless Steel Loadcell
- 310mm x 310mm Pan
- X320 or R420 Indicator

CAPACITIES

- 30kg x 0.002kg
- 60kg x 0.005kg

DIMENSIONS

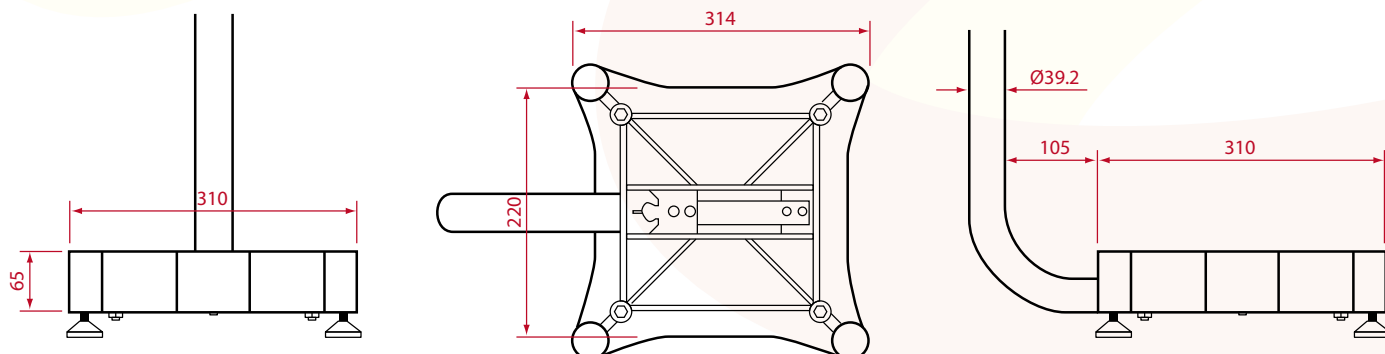

SPECIFICATIONS

PRODUCT	XS-A	XT-A	
Loadcell IP Rating	IP-67	IP-68 or IP-69K	
Capacity	30kg x 0.002kg or 60kg x 0.005kg		
Pan Size (L x W x H)	310mm x 310mm x 80mm		
Materials	6mm frame - 8mm plate		
Frame	304 Stainless Steel		
Pan	304 Stainless Steel		
Feet	304 Stainless Steel		
Loadcell	Stainless Steel		
INDICATOR	R420		
Repeatability	±1 Division		
Linearity	±1 Division		
Display	LCD with 4 Alphanumeric Displays and LED Backlighting: Primary Display: 6 x 28.4mm-High Digits with Units and Annunciators Second Display: 9 x 17.6mm Digits with Units Third Display: 8 x 6.1mm Digits Fourth Display: 4 x 7.6mm Digits		
Keypad	23 Silicon Keys		
Ambient Temperature	-10°C - +40°C		
DC	12 to 24VDC (15VA Max.) ON/OFF Key with Memory Feature		
AC	AC Power Supply, Input: 110/240VAC 50/60Hz, Output: 12VDC 15VA		
Battery	2.5Ah NiMH Rechargeable Battery Pack Charger Input: 110/240VAC 50/60Hz, Output: 12VDC		
Indicator IP Rating	IP-65		
Data Output	Serial 1A: RS-232 Serial Port for Remote Display, Network or Printer. Serial 1B: RS-485 Transmit Only for Remote Display Transmission Rates: 2,400, 4,800, 9,600 or 19,200 Baud		
SOFTWARE	K401	K402	K411
Functions	Custom Printing, Custom Unit Switching, Counting, Manual Hold, Peak Hold, Auto Output and Totalising, Printing, Auto Output	6-Material, Inflight and Jogging Correction, 3-Speed Fill, Up to 10 Batching Stages Fill, DumpWait and Pulse Stages	
Setpoints	-	8	
Analogue Output	-	1 (Optional Module)	
Other Communications	-	Optional Modules RS-232/RS-232 RS-232/RS-485 RS-485/RS-485	
Button Inputs	-	4 Buttons (Optional Module)	

Accuweigh Pty Ltd

WESTERN AUSTRALIA (HEAD OFFICE):
PHONE: (08) 9259 5535

SOUTH AUSTRALIA OFFICE:
PHONE: (08) 8447 5011

NEW SOUTH WALES (SYDNEY) OFFICE:
PHONE: (02) 9728 4877



www.accuweigh.com.au

VICTORIA OFFICE:
PHONE: (03) 9548 5554

NEW SOUTH WALES (NEWCASTLE) OFFICE:
PHONE: (02) 4966 8900

QUEENSLAND OFFICE:
PHONE: (07) 3265 5520