

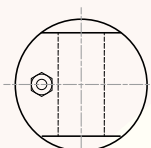

FEATURES

- Fully Sealed Tool Steel
- Popular Weighbridge Model
- Ideal for Tanks and Hoppers
- Rugged Construction
- Tough PUR Sheathed Cable



LEFT SIDE VIEW

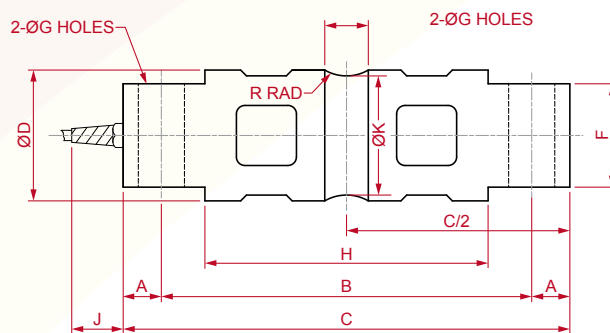

FRONT VIEW

CABLE

COLOUR	DESIGNATION
Red	+ Excitation
Black	- Excitation
Green	+ Signal
White	- Signal

4.5mm-5mm, Screened, PUR Sheath, 4-Core

Capacity	A	B	C	D	E	F	G	H	J	K	R	Weight
20klb (9,072kg)	15.7	174.6	206.2	49.5	21.3	28.4	16.7	133.1	30.0	37.6	12.7	2.35kg
30klb (13,608kg) 40klb (18,144kg)	22.4	215.9	260.4	76.2	25.4	60.2	26.9	165.1	30.0	69.3	25.4	7.5kg
50klb (22,679kg) 60klb (27,216kg) 75klb (34,020kg)	22.4	215.9	260.4	76.2	25.4	60.2	26.9	165.1	30.0	69.3	25.4	7.6kg
100klb (45,360kg)	22.4	241.3	285.8	88.9	31.0	63.5	26.9	190.2	30.0	82.3	38.1	11.5kg
150klb (68,040kg)	22.4	241.3	285.8	99.1	31.0	71.1	26.9	190.2	30.0	92.5	38.1	13.9kg

All Dimensions in mm Unless Noted Otherwise

TECHNICAL DATA

Signal Output at Capacity	3mV/V ±0.03mV
Linearity Error	<0.017% FSO
Non-Repeatability	<0.010% FSO
Combined Error	<0.020% FSO
Hysteresis	<0.020% FSO
Creep (30 Minutes)	<0.020% FSO
Zero Balance	<1% Capacity
Temperature Effect on Span (/10°C)	<0.014% FSO
Temperature Effect on Zero (/10°C)	<0.018% FSO
Operating Temperature Range	-35°C to +65°C
Storage Temperature	-50°C to +85°C

Service Load	100% Capacity
Safe Load	150% Capacity
Safe Side Load	100% Capacity
Ultimate Load	300% Capacity
Input Resistance	700Ω ±7Ω
Output Resistance	700Ω ±7Ω
Insulation Resistance	>5,000MΩ @ 50VDC
Excitation Voltage (Recommended)	9V to 12V AC/DC
Excitation Voltage (Maximum)	18V AC/DC
Material	Tool Steel
Sealing	IP-67

Accuweigh Pty Ltd

WESTERN AUSTRALIA (HEAD OFFICE):
PHONE: (08) 9259 5535

SOUTH AUSTRALIA OFFICE:
PHONE: (08) 8447 5011

NEW SOUTH WALES (SYDNEY) OFFICE:
PHONE: (02) 9728 4877



www.accuweigh.com.au

VICTORIA OFFICE:
PHONE: (03) 9548 5554

NEW SOUTH WALES (NEWCASTLE) OFFICE:
PHONE: (02) 4966 8900

QUEENSLAND OFFICE:
PHONE: (07) 3265 5520

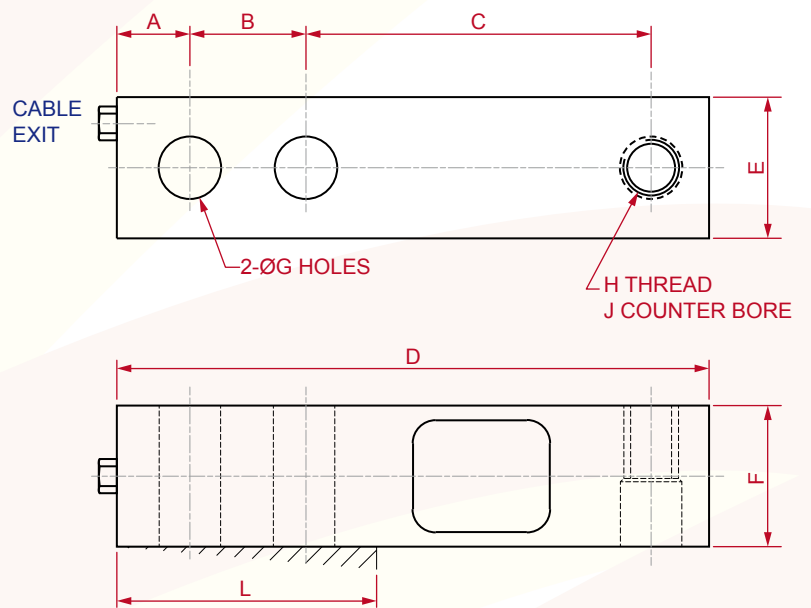

MOUNTING ACCESSORIES

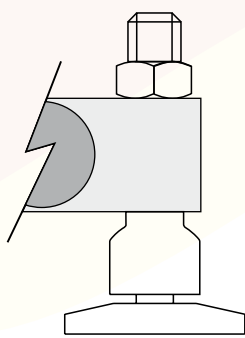

SWIVEL FOOT

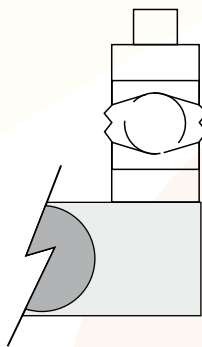

BALL & CUP

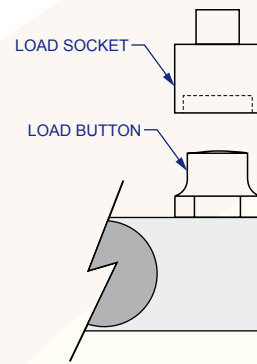

LOAD SOCKET &
BUTTON