



### DESCRIPTION

The PT3000 Series has a high number of specific capacities and low-sensitivity to off-centre loading allowing better selection for accuracy in high-speed weighers, check weighers, hopper scales and net weighers.

THE PT3000 Series is available in nine capacities from 50kg to 635kg with a maximum platform size of 600mm x 600mm.

This is a perfect loadcell for the light to medium bench and platform scale market. Used extensively in process weighing, check weighing, bag filling and overhead track weighing.

The PT3000 is a robustly constructed marine grade anodised cell with SURESEAL protection to IP-66.

### APPLICATIONS

- Bench and Platform Scales
- Check Weighers and Bag Fillers
- Process Weighing

### FEATURES

- Marine Grade Anodised
- Protected with SURESEAL™
- Compact Size, Metric Thread
- Generous Platform Sizes Up to 600mm x 600mm



### TECHNICAL DATA

Signal Output at Capacity	2mV/V ±10%
Linearity Error	<0.020% FSO
Non-Repeatability	<0.010% FSO
Combined Error	<0.025% FSO
Hysteresis	<0.015% FSO
Creep/Zero Return (30 Minutes)	<0.030%/0.020% FSO
Zero Balance	<3% Capacity
Temperature Effect on Span (/10°C)	<0.010% FSO
Temperature Effect on Zero (/10°C)	<0.015% FSO
Operating Temperature Range	-30°C to +70°C
Compensated Temperature Range	-10°C to +40°C
Storage Temperature	-50°C to +70°C

Service Load	100% Capacity
Safe Load	150% Capacity
Ultimate Load	250% Capacity
Input Resistance	425Ω ±15Ω
Output Resistance	350Ω ±3Ω
Insulation Resistance	>5,000MΩ @ 100VDC
Excitation Voltage (Recommended)	5V to 12V AC/DC
Excitation Voltage (Maximum)	15V AC/DC
Eccentric Loading (Effect/cm)	<0.005% FSO
Deflection at Rated Capacity	<0.4mm
Material	Aluminium
Finish	Marine Anodised
Sealing	IP-66
Net Weight	1.85kg

# DIMENSIONS

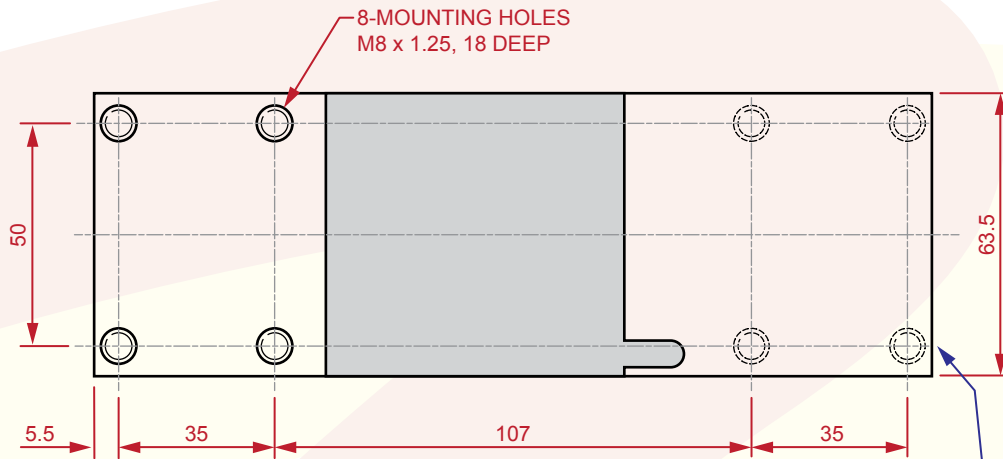

**TOP VIEW**

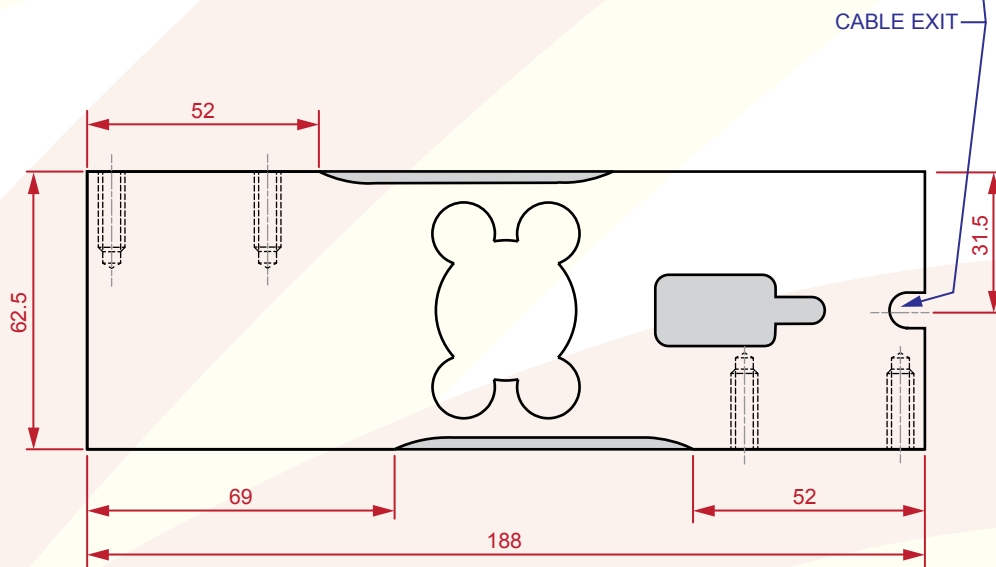

**FRONT VIEW**

## CABLE

COLOUR	DESIGNATION
Red	+ Excitation
Black	- Excitation
Green	+ Signal
White	- Signal

Type: 4mm, Screened, PVC Sheath,  
0.09mm<sup>2</sup> (28 AWG)

Length: 3m

**Accuweigh Pty Ltd**

WESTERN AUSTRALIA (HEAD OFFICE):  
PHONE: (08) 9259 5535

SOUTH AUSTRALIA OFFICE:  
PHONE: (08) 8447 5011

NEW SOUTH WALES (SYDNEY) OFFICE:  
PHONE: (02) 9728 4877



[www.accuweigh.com.au](http://www.accuweigh.com.au)

VICTORIA OFFICE:  
PHONE: (03) 9548 5554

NEW SOUTH WALES (NEWCASTLE) OFFICE:  
PHONE: (02) 4966 8900

QUEENSLAND OFFICE:  
PHONE: (07) 3265 5520