



DRIVE&WEIGH 8000

Certifiable In-Motion Weighbridge!

ACCUWEIGH

Onboard and Vehicle
Weighing Systems

SOLUTIONS PROVIDER FOR
CHAIN OF RESPONSIBILITY



DESCRIPTION

Ideal for the Transport Industry, Waste Industry, Forestry Industry, Demolition and Excavation Industry, Marine and Ports, etc.

In eliminating overloading, the **DRIVE&WEIGH** can also deliver improved site safety which can have a positive impact for insurance purposes.

FLEET OPERATION

DRIVE&WEIGH is ideal for detecting overloading of vehicles and therefore is an effective prevention against fines for both axle and total load infringements.

Fleet operators also find the **DRIVE&WEIGH** useful for the prevention of under loading, therefore encouraging plant operators to improve efficiencies by maximising payloads.

PERIPHERAL EQUIPMENT

DRIVE&WEIGH can be integrated with any control barriers, traffic lights, signs and cameras to meet the most demanding application.

CERTIFIABLE!

Class **IV**

For legal purposes other than for trade measurement.

SPECIFICATIONS

DECK STRUCTURE

- Standard: 3000mm x 730mm x 240mm
- Special sizes and dual platforms available on request
- Capacities: 25,000kg / Heavy Duty 40,000kg
- Surround Frame: 3,252mm x 902mm x 350mm

WEIGHT

Standard:	860kg
Heavy-Duty:	890kg
Steel Pit Frame:	340kg

LOADCELLS

4 x 10,000kg standard or heavy duty stainless steel fully welded cells are each fitted into a unique tension mounting assembly. Assemblies are powder coated cast iron with stainless steel load pins.

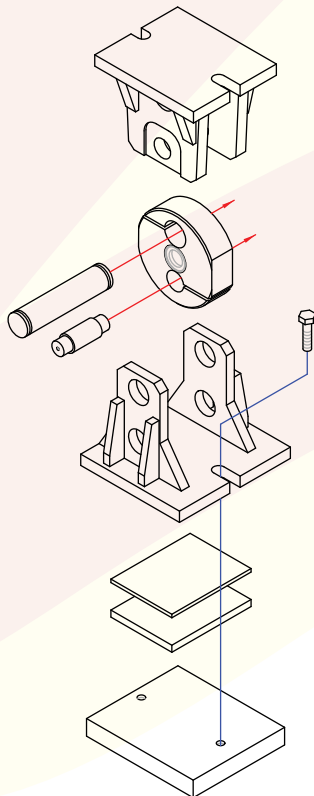

LOADCELL DESIGN

INSTRUMENTATION

- Stainless steel enclosure with IP-65 protection
- Alphanumeric keyboard and display
- 4 x outputs selectable from 20mA Current Loop, RS-232, RS-422, or RS-485
- Display increment 10kg
- Over speed and over weight
- Full fault diagnostics display
- Optional:
 - Ethernet
 - DeviceNET
 - ProfiBUS DP
 - PC Keyboard
 - Detection of direction of travel



OPERATING SPEED

0 to 15kph restricted to 5kph for Law Enforcement and Legal Axle Loading Applications.

ACCURACY

- Static: ±5kg to 5,000kg
- Static: ±10kg to 20,000kg
- Dynamic: ±1% (site dependent)

MISCELLANEOUS

Operating Temperature: -10°C to +60°C
Safe Overload Rating: 150%



Accuweigh Pty Ltd

WESTERN AUSTRALIA (HEAD OFFICE):
PHONE: (08) 9259 5535

SOUTH AUSTRALIA OFFICE:
PHONE: (08) 8447 5011

NEW SOUTH WALES (SYDNEY) OFFICE:
PHONE: (02) 9728 4877



www.accuweigh.com.au

VICTORIA OFFICE:
PHONE: (03) 9548 5554

NEW SOUTH WALES (NEWCASTLE) OFFICE:
PHONE: (02) 4966 8900

QUEENSLAND OFFICE:
PHONE: (07) 3265 5520