

CAS SW-1W WATERPROOF SCALES

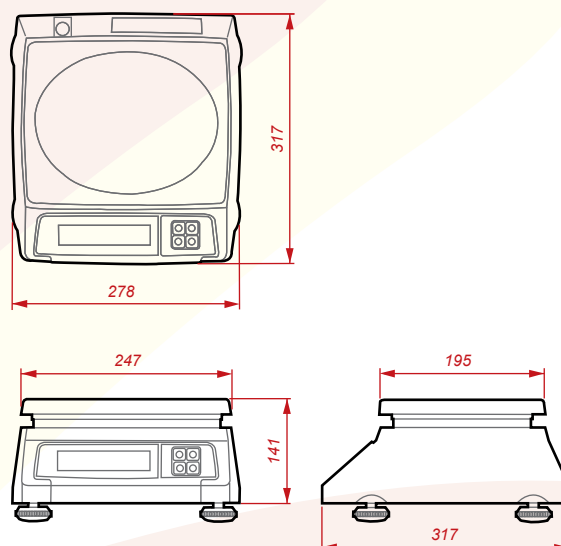

DIMENSIONS



FEATURES

- Battery Operation with Auto Power Off Feature
- Large 25mm LCD Display
- Selectable Units (lb / g / kg / oz)
- Soft Touch Tack Switch
- Compact Design and Stainless Steel Platter
- Zero, Net, Stable, Low Battery Indicators
- Function: On/Off, Zero, Tare, Unit.

SPECIFICATIONS

MODEL	SW-1W-05	SW-1W-10	SW-1W-20
Capacity	5 kg x 0.002 kg	10 kg x 0.005 kg	20 kg x 0.01 kg
Divisions	1/2500	1/2000	1/2000
Maximum Tare	Full Capacity		
Display	5 Digit LCD (25mm)		
Display Designators	Stable, Zero, Net, Low Battery		
Measurement Type	Load Cell		
Power Source	DC 9V (6 x 1.5V) / AC Adapter Included		
Power Consumption	0.25W		
Operating Time	Alkaline Dry Battery: 1600 hr Manganese Battery: 800 hr		
Operating Temperature	-10°C ~ +40°C		
Platter Size	247mm(W) x 195mm(D)		
Dimensions	278mm(W) x 317mm(D) x 141mm(H)		
Product Weight	3.7kg		

Accuweigh Pty Ltd

WESTERN AUSTRALIA (HEAD OFFICE):
PHONE: (08) 9259 5535

SOUTH AUSTRALIA OFFICE:
PHONE: (08) 8447 5011

NEW SOUTH WALES (SYDNEY) OFFICE:
PHONE: (02) 9728 4877



www.accuweigh.com.au

VICTORIA OFFICE:
PHONE: (03) 9548 5554

NEW SOUTH WALES (NEWCASTLE) OFFICE:
PHONE: (02) 4966 8900

QUEENSLAND OFFICE:
PHONE: (07) 3265 5520