

# AVERY T203 SHEARBEAM LOADCELL

by  
**Avery Weigh-Tronix**

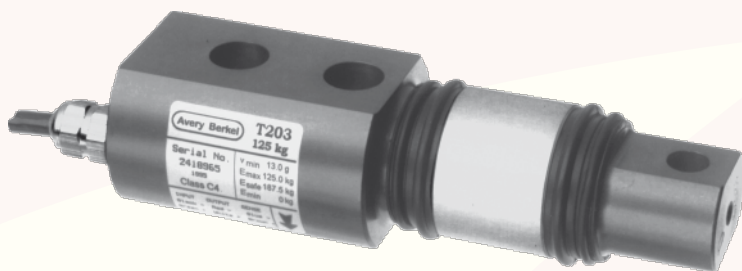

## HIGHLIGHTS

- Capacities of 125kg, 250kg and 500kg
- Exceptional Accuracy (1/4,000)
- Low Profile, Simple to Install
- Insensitive to Side Loads
- Excellent Repeatability
- Small Creep and Hysteresis Errors
- Output Matched During Calibration
- Special Version Approved for Use in Hazardous Areas to CENELEC Standards
- IP-65 and IP-67 Rated
- Hard Anodised Aluminium Alloy Construction for Exceptional Corrosion Resistance
- Strain Gauges Encapsulated in Butyl Rubber and Sealed with a Neoprene Gaiter

## DESCRIPTION

The T203 Series is a high precision, single bridge strain gauge shearbeam loadcell designed for use in low profile platform scales and conversions of mechanical scales. These robust loadcells are protected against the ingress of dust and water for the toughest environments.

## APPLICATIONS

- Low Profile Platform Scales
- Loadcell in Mechanical Scale Conversions
- Hoppers, Tanks and Silos
- Overhead Track Scales
- Dynamometers

## DIMENSIONS

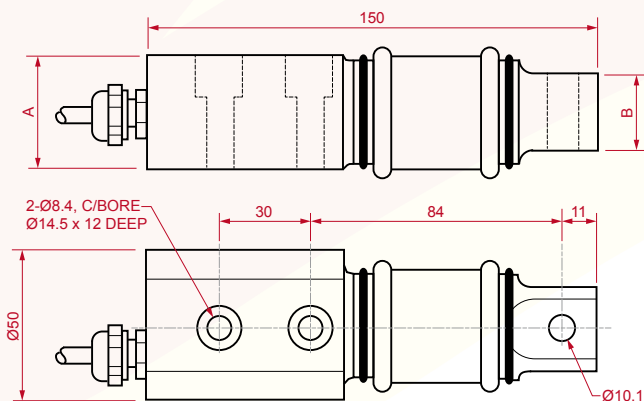

		125kg, 250kg	500kg
+SENSE	BROWN	A	42
-SENSE	BLUE		
+EXCITATION	GREEN	B	30
-EXCITATION	BLACK		
+SIGNAL	WHITE		
-SIGNAL	RED		

## SPECIFICATIONS

Rated Output	1.4mV/V $\pm 0.1\%$ (125kg) 1.7mV/V $\pm 0.1\%$ (250kg, 500kg)
Maximum Safe Overload	150% of Rated Capacity
Maximum Side Load	50% of Rated Capacity
Combined Error	$\pm 0.012\%$ of Rated Capacity
Zero Balance	$\pm 1\%$ of Rated Capacity
Repeatability	0.01% of Rated Capacity
30 Minute Creep	$\pm 0.0125\%$ of Rated Output
Recommended Excitation Voltage	10V DC or AC
Maximum Excitation Voltage	15V DC or AC
Input Terminal Resistance	410 $\Omega$ Nominal
Output Terminal Resistance	350 $\Omega$ Nominal
Insulation Resistance	Greater Than 5000M $\Omega$
Temperature Effect on Zero	0.001% of Rated Output/10 $^{\circ}$ C
Temperature Effect on Span	0.0025% of Rated Output/10 $^{\circ}$ C
Deflection at Rated Load	0.4mm Nominal

**Accuweigh Pty Ltd**

WESTERN AUSTRALIA (HEAD OFFICE):  
PHONE: (08) 9259 5535

SOUTH AUSTRALIA OFFICE:  
PHONE: (08) 8447 5011

NEW SOUTH WALES (SYDNEY) OFFICE:  
PHONE: (02) 9728 4877



[www.accuweigh.com.au](http://www.accuweigh.com.au)

VICTORIA OFFICE:  
PHONE: (03) 9548 5554

NEW SOUTH WALES (NEWCASTLE) OFFICE:  
PHONE: (02) 4966 8900

QUEENSLAND OFFICE:  
PHONE: (07) 3265 5520