

AVERY E1205 & E1210 DIGITAL INDICATORS



E1205



E1210

DESCRIPTION

The E1205 and E1210 intelligent indicators are designed to analyse, store, display and transmit data between applications and across networks - giving you greater visibility of process performance.

The E1205 and E1210 are advanced multi-function models designed for ultimate ease of use, providing all the flexibility and connectivity you need to control any weight-based process in your business.

HIGHLIGHTS

- Piece weighing, counting, checkweighing and 3-level pack run functions
- Advanced weighbridge programme with full database
- Comprehensive recipe formulation programme with 300 PLUs
- Superb graphics display for ultimate flexibility and ease of use
- Serial port, Ethernet and FieldBus connectivity - electronic archiving also available
- Stainless steel version available for IP-65 applications (E1210)

DIMENSIONS

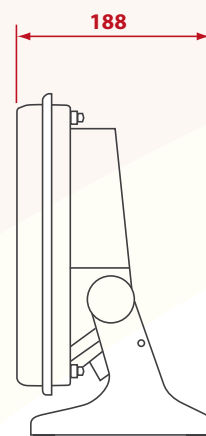
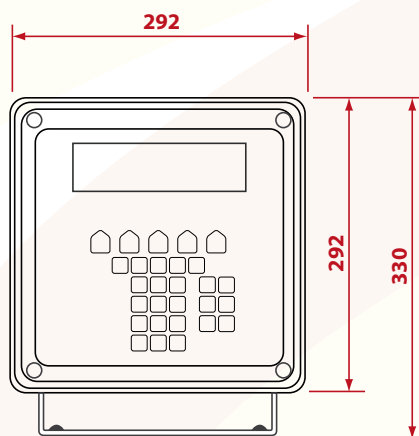
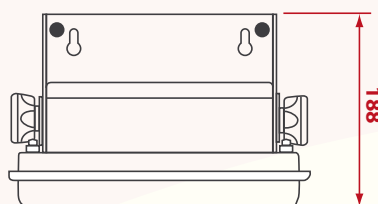

by
Avery Weigh-Tronix

FEATURES

■ Improve Profitability

E1205 and E1210 give you the power to improve profitability and efficiency in numerous weighing processes across the food, pharmaceutical, chemical, logistics, mining, waste, metals and engineering industries.

■ Advanced Multi-function Value

The optimum solution for piece weighing, process control, checkweighing, counting and totalising.

■ Total Weighbridge Control

The indicators offer total control of your weighbridge operation. A comprehensive database allows you track vehicles, materials, suppliers and customers.

■ Recipe Formulation - No Problem!

Even complex recipe routines are trouble-free. The indicators hold 100 recipes of up to 20 stages each - plus 300 PLUs to store ingredients.

■ Manage Packing Runs

Three levels of pack runs help you manage packing operations fully.

■ Flexible Trips

Up to 16 fully-configurable trips provide all the flexibility you need to manage a wide range of process control and formulation routines.

■ Accurate Results - Every Time

E1205 and E1210 are designed to be the most operator-friendly indicators on the market. From simple weighing to process management, the graphical display gives clear results and prompts at every stage.

■ Ultimate Ease of Use

With five function keys to speed configuration and operation, the indicators provide fast, error-free results. The alpha keypad is ideal for occasional use or alternatively, a PC keyboard can be connected for frequent data entry.

■ IP-65 Hose-Proof Model

Stainless steel E1210 version suits IP65 applications, with the same levels of functionality as E1205.

■ Complete Connectivity

With inputs for up to 12 load cells, the indicators address the vast majority of weighing requirements - and can control a second weigh scale. The three internal 230 V-rated outputs can be expanded to up to 16 inputs/outputs via software.

■ Flexible Communications

For communication to printers, PCs and other devices, the indicators offer two serial ports and Ethernet connectivity as standard. Two further optional serial ports and a Fieldbus connection of your choice may be added.

■ Less Downtime - Lower Costs

Intelligent design and PC-based service tools ensure rapid installation and configuration, reduced downtime and easy upgrading.



Accuweigh Pty Ltd

WESTERN AUSTRALIA (HEAD OFFICE):
PHONE: (08) 9259 5535

SOUTH AUSTRALIA OFFICE:
PHONE: (08) 8447 5011

NEW SOUTH WALES (SYDNEY) OFFICE:
PHONE: (02) 9728 4877



www.accuweigh.com.au

VICTORIA OFFICE:
PHONE: (03) 9548 5554

NEW SOUTH WALES (NEWCASTLE) OFFICE:
PHONE: (02) 4966 8900

QUEENSLAND OFFICE:
PHONE: (07) 3265 5520