



CHECKWEIGHER MODEL 01D3

OVERVIEW

The AccuCheck 01D3 Checkweigher is a high-speed, stainless steel unit with powerful statistical collection and analysis.

HIGHLIGHTS

- Digital Electronics with Alphanumeric Graphic Display Panel
- Electronic Self-Calibration Device
- Production Data Management in Conformity with the Standards in Force
- Speed Adjustable from Keypad
- Mobile Average Function
- 100 Storable Product Programs
- Conveyors Easily Removable

Capacity	600g
Linear Speed	100m/Minute
Throughput	Up to 500 Pieces/Minute
Display Division	0.1g to 0.2g
Accuracy	±0.1g
Pneumatic Supply	0.6MPa
Air Consumption (for Ejection System)	1NI
Power Supply	230VAC 50/60Hz Single-Phase
Power Consumption	700W
Finishes	Stainless Steel IP55 to IP66



OPTIONS

- Ejection Systems
- Reject Management Systems
- RS-232 Serial Port
- USB Port
- In-Feed and Out-Feed Conveyors
- Wind-Prevention Tunnel
- Feedback Function
- 24-Column Panel Printer
- Open Flap Control Device
- Data Collection via Network
- Conformity with Standards ISO-FDA-HACCP

DIMENSIONS

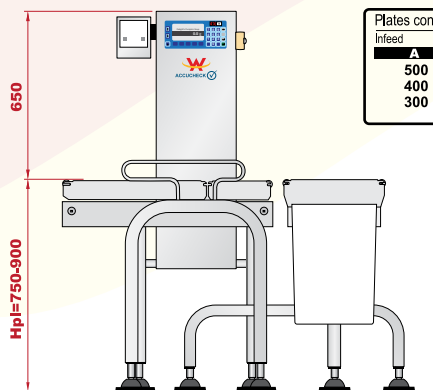

Plates configuration			
Infeed	Weighing		Outfeed
A	B	C	
500	100	300-400	
400	200	300-400	
300	300	300-400	

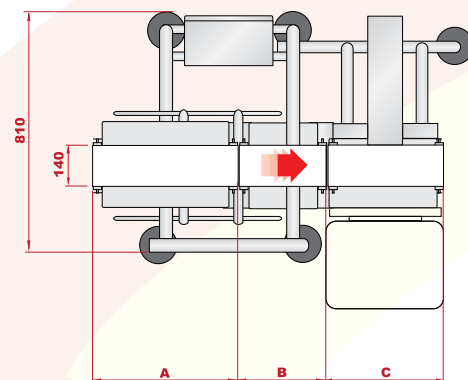

Accuweigh Pty Ltd

WESTERN AUSTRALIA (HEAD OFFICE):
PHONE: (08) 9259 5535

SOUTH AUSTRALIA OFFICE:
PHONE: (08) 8447 5011

NEW SOUTH WALES (SYDNEY) OFFICE:
PHONE: (02) 9728 4877



www.accuweigh.com.au

VICTORIA OFFICE:
PHONE: (03) 9548 5554

NEW SOUTH WALES (NEWCASTLE) OFFICE:
PHONE: (02) 4966 8900

QUEENSLAND OFFICE:
PHONE: (07) 3265 5520