

# SJ-HS SERIES DIGITAL SCALE



## APPLICATIONS

Food service, Stores, Post offices, Industries, Factories, Schools, Laboratories, Warehouses, Offices, Home use and a wide range of other diverse weighing applications are possible.

## FEATURES

- High Resolution
- Fast Stability Time - Less than 1 Second
- Large, Wide LCD Display (25mm Height)
- Durable Body
- Large Weighing Pan: 230mm x 790mm
- Full Digital Calibration Function
- Multiple Weighing Units - g, lb, oz and lb/oz
- Battery Operation with 4 x D Size Dry Cell Batteries
- Simple and Easy to Change the Batteries
- Optional AC Adaptor
- Automatic Power OFF Function
- Spirit Level and Adjustable Feet for Accurate Weighing
- Status Indication Function - Battery, Stable, Zero and Net

## MODELS

MODEL	CAPACITY/DIVISIONS
SJ-1000HS	1,000g x 0.5g
SJ-2000HS	2,000g x 1g
SJ-5000HS	5,000g x 2g
SJ-12KHS	12kg x 0.005kg

## ACCESSORIES

- AX-TB164B: AC Adaptor AC230V C-Type Plug
- AX-TB173A: AC Adaptor AC230V BF Type Plug
- AX-TB196: AC Adaptor AC100V A Type Plug
- AX-TB202: AC Adaptor AC120V A Type Plug

# SPECIFICATIONS

MODEL	SJ-1000HS	SJ-2000HS	SJ-5000HS	SJ-12KHS
Capacity/Divisions	1,000g x 0.5g	2,000g x 1g	5,000g x 2g	12kg x 0.005kg
	2.2lb x 0.001lb	4.4lb x 0.002lb	11lb x 0.005lb	26lb x 0.01lb
	35oz x 0.02oz	70oz x 0.05oz	176oz x 0.1oz	423oz x 0.2oz
	2.2lb x 0.1oz	4.4lb x 0.1oz	11lb x 0.1oz	26lb x 1oz
Linearity	±1g	±2g	±5g	±10g
Repeatability	1g	2g	5g	10g
Span Drift	0.015%/°C Typical			
Display	Liquid Crystal Display, 25mm High Digits			
Operating Temperature	-10°C to +40°C			
Display Update Rate	Approximately 10 Times per Second			
Weight	2.1kg			
Calibration Mass	1,000g	2,000g	5,000g	10,000g

# DIMENSIONS

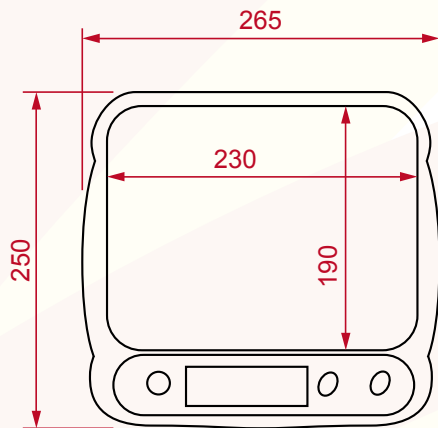

**TOP VIEW**

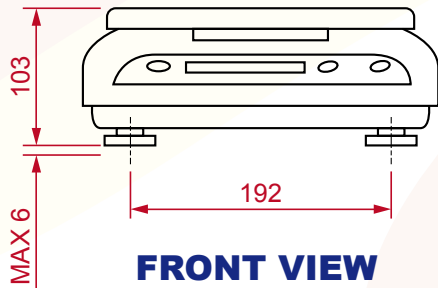

**FRONT VIEW**

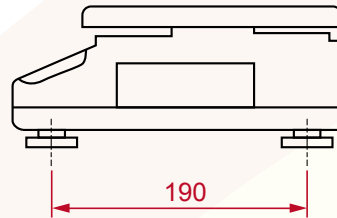

**SIDE VIEW**

## Accuweigh Pty Ltd

WESTERN AUSTRALIA (HEAD OFFICE):  
PHONE: (08) 9259 5535

SOUTH AUSTRALIA OFFICE:  
PHONE: (08) 8447 5011

NEW SOUTH WALES (SYDNEY) OFFICE:  
PHONE: (02) 9728 4877



[www.accuweigh.com.au](http://www.accuweigh.com.au)

VICTORIA OFFICE:  
PHONE: (03) 9548 5554

NEW SOUTH WALES (NEWCASTLE) OFFICE:  
PHONE: (02) 4966 8900

QUEENSLAND OFFICE:  
PHONE: (07) 3265 5520