

SB SERIES

IP-65 BASEWORKS

The SB Series is a water- and dust-proof platform basework protected to IP-65. Models include the SB-15K10-D, SB-60K11-D, SB-100K12-D and SB-200K12-D.



by 
A&D MERCURY PTY LTD

SPECIFICATIONS

MODEL	SB-15K10-D	SB-60K11-D	SB-100K12-D	SB-200K12-D
Capacity	15kg	60kg	100kg	220kg
Pan Size	250mm x 250mm	330mm x 424mm	390mm x 530mm	
Zero Balance	0.2mV/V ±0.1mV/V	0.16mV/V ±0.1mV/V	0.16mV/V ±0.1mV/V	0.13mV/V ±0.1mV/V
Rated Output	1mV/V ±10%			
Linearity and Hysteresis	0.03% of Rated Output			
Comp. Temperature Range	-10°C to +40°C			
Maximum Excitation Voltage	15VDC			
Input Terminal Resistance	1,190Ω ±50Ω			
Output Terminal Resistance	1,000Ω ±10Ω			
Insulation Resistance	Greater than 5,000MΩ at 50VDC			
Cable	Ø4mm x 3m, Shielded Cable with 4-Conductors			
Approx. Platform Mass	4.5kg	8.0kg	14kg	
Weigh Pan Material	Stainless Steel			
Base Unit Material	Plastic/Stainless Steel	Aluminium Alloy Die-Castings		

DIMENSIONS

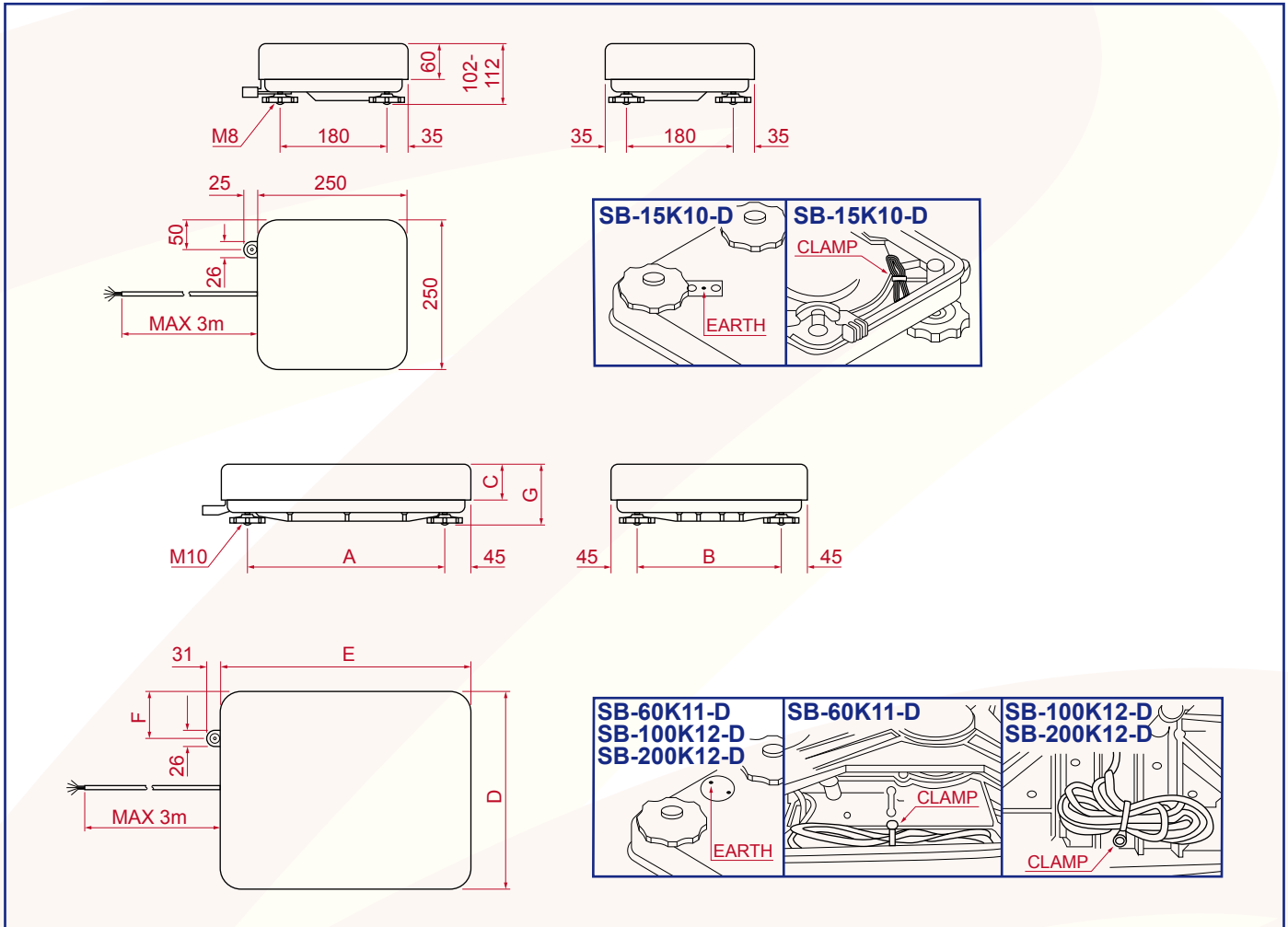

DIM	SB-60K11-D	SB-100K12-D SB200K12-D
A	334	440
B	240	300
C	55	70
D	330	390
E	424	530
F	85	115
G	105-115	120-139

CABLE COLOUR CODES

COLOUR	WIRE DESIGNATION
Red	+ Excitation (Input Terminal)
White	- Excitation (Input Terminal)
Green	+ Signal (Output Terminal)
Blue	- Signal (Output Terminal)
Yellow	Shield

Accuweigh Pty Ltd

WESTERN AUSTRALIA (HEAD OFFICE):
PHONE: (08) 9259 5535

SOUTH AUSTRALIA OFFICE:
PHONE: (08) 8447 5011

NEW SOUTH WALES (SYDNEY) OFFICE:
PHONE: (02) 9728 4877



www.accuweigh.com.au

VICTORIA OFFICE:
PHONE: (03) 9548 5554

NEW SOUTH WALES (NEWCASTLE) OFFICE:
PHONE: (02) 4966 8900

QUEENSLAND OFFICE:
PHONE: (07) 3265 5520