



FZ-i & FX-i SERIES PRECISION BALANCES

The FZ-i Series (with automatic self calibration) and FX-i Series (manual calibration), and their IP-65 counterparts (the FZ-iWP and FX-iWP) provide a powerful and versatile range of Precision Balances.

The FZ-i/FX-i Series are a new addition to **AND** Precision Balances and rivals the GX/GF Series in performance and quality, but offers higher accessibility, bringing to you a cost-effective solution for a diverse array of applications.



by
AND
A&D MERCURY PTY LTD



FZ-i & FX-i

- Internal Test Mass for Automatic Self Calibration (FZ-i Series)
- Dual Interval (0.1mg/0.01mg)
- 250g Capacity

FZ-iWP & FX-iWP

- IP-65 for use in wet or dusty areas
- Internal Test Mass for Automatic Self Calibration (FZ-iWP Series)

MODEL	FX-120i FX-120iWP FZ-120i FZ-120iWP	FX-200i FX-200iWP FZ-200i FZ-200iWP	FX-300i FX-300iWP FZ-300i FZ-300iWP	FX-1200i FX-1200iWP FZ-1200i FZ-1200iWP	FX-2000i FX-2000iWP FZ-2000i FZ-2000iWP	FX-3000i FX-3000iWP FZ-3000i FZ-3000iWP
Capacity	122g	220g	320g	1,220g	2,200g	3,200g
Resolution	1mg			10mg		
Repeatability	1mg			10mg		
Linearity	±2mg			±20mg		
Sensitivity Drift	±2ppm/°C					
Approx. Stabilisation Time	Minimum 1s but selectable					
Weighing Units	g, oz, lb, L oz, ozt, ct, dwt, mom, GN, tola, tael, mes, MLT, %, pcs					

Looking for higher capacities? Check out the GP Series High-Capacity Precision Balance Range.

FEATURES



Ethernet Hub
(Supplied by End User)



OPTIONS

- FXi-02*: Quick USB Interface with Cable
- FXi-08*: Ethernet Interface with Win-CT-Plus Software
- FXi-09*: Built-in Rechargeable Battery
- FXi-10: Small Breeze Break
- FXi-11: Large Breeze Break
- FXi-12: Animal Weighing Pan (FZ,FX-1200i / 2000i / 3000i)
- FXi-15: Carry Case

* FXi-02, FXi-08 and FXi-09 cannot be used at the same time.

DIMENSIONS

Pan Size	Model	A
FZ,FX-120i / 200i / 300i		Ø130
FZ,FX-1200i / 2000i / 3000i		Ø150

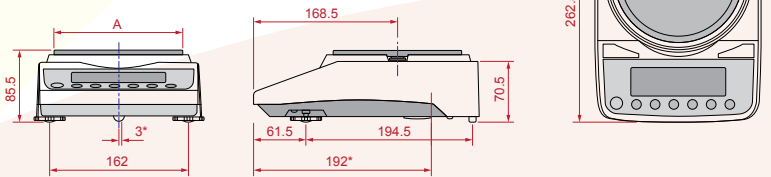

Dimensions with Small Breeze (Accessory FXi-10)

(Supplied as Standard with FZ,FX-120i/200i/300i, FZ-1200i/2000i/3000i)

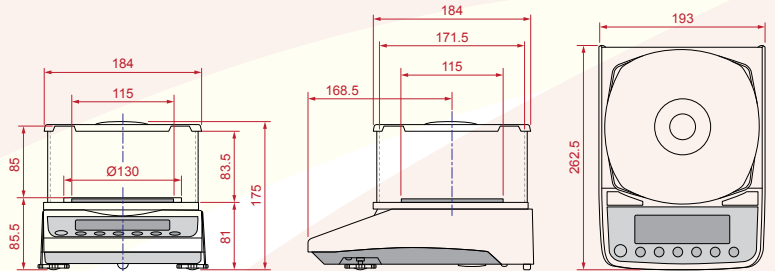

PERIPHERALS

- AD-1683: Static Eliminator
- AD-1684: Electrostatic Field Meter
- AD-1689: Tweezers for Calibration Weight
- AD-8920: Remote Display
- AD-8922: Remote Display and Controller
- AD-8121B: Dot Matrix Compact Printer
- AD-8118C: Universal Printer
- AX-KO2466-200: RS-232 Cable (9-Pin to 9-Pin)
- AD-8526: Serial/Ethernet Converter
- AX-USB-9P: Serial/USB Converter
- AX-CARATPAN-W: Carat Pan (Silver, 2-Pieces)
- AX-CARATPAN-B: Carat Pan (Black, 2-Pieces)
- AX-FXi-31: Main Unit Cover (5-Pieces)

Dimensions with Large Breeze (Accessory FXi-11)

Optional Extra

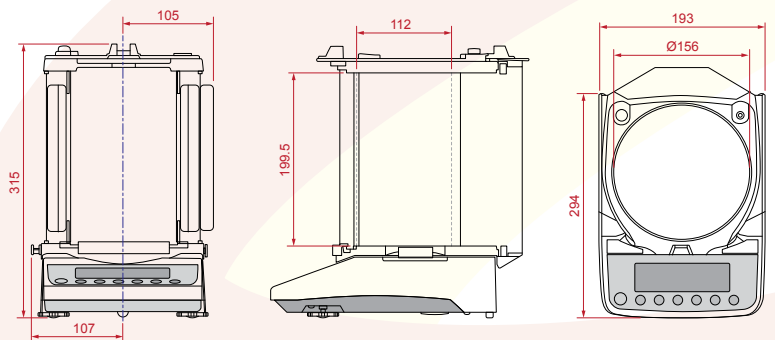

Accuweigh Pty Ltd

WESTERN AUSTRALIA (HEAD OFFICE):
PHONE: (08) 9259 5535

SOUTH AUSTRALIA OFFICE:
PHONE: (08) 8447 5011

NEW SOUTH WALES (SYDNEY) OFFICE:
PHONE: (02) 9728 4877



www.accuweigh.com.au

VICTORIA OFFICE:
PHONE: (03) 9548 5554

NEW SOUTH WALES (NEWCASTLE) OFFICE:
PHONE: (02) 4966 8900

QUEENSLAND OFFICE:
PHONE: (07) 3265 5520