

### HIGHLIGHTS

- Trade Approved (NMI 6/4C/250)
- IP-65 Dustproof and Waterproof
- Comparator Functionality Ideal for Check Weighing



by **AND**  
A&D MERCURY PTY LTD

### FEATURES

- Ultra fast response time of just 0.5 seconds.
- Three comparator lights to easily identify weighing results and improve productivity.
- IP-65 with stainless steel weigh pan and display unit.
- Tilting head for optimum readability.
- Comparator function allowing the input of a Target Weight for check weighing.
- Three different-coloured comparator lights for low, OK and high weight zones for fast and easy check weighing result verification.
- Analog Sweep Display (ASD): 60-segment LCD showing simple weighing, target weighing or limit check weighing.
- Back lighting of all displays for reading in dim light.
- Approved by NMI for trade measurement with 3000 divisions.
- Selectable weighing resolutions of 1/3,000 normal resolution, 1/6,000 or 1/7,500 (depending on model) high resolution or 1/12,000 or 1/15,000 (depending on model) highest resolution.
- Selectable weighing units: kg, g, lb, oz, lb:oz.
- Preset tare using the numeric keypad.
- Optional Sealed Lead Acid battery for operation up to 80 hours. 15 hours recharge time.
- Auto power off function (after five minutes of displaying zero) to conserve battery life.
- 100 Target Weight memory function for efficient check weighing.
- Level bubble fitted for accurate scale levelling.
- Interface capability with optional relay outputs and RS232/422/485 for process line control.
- Buzzer output for audible feedback on keypad use and comparator status.

# SPECIFICATIONS

MODEL	FS-6Ki			FS-15Ki			FS-30Ki		
Weighing Capacity	6kg			15kg			30kg		
Selectable Division * Default Factory Set	0.0005kg	0.001kg	0.002kg*	0.001kg	0.002kg	0.005kg*	0.002kg	0.005kg	0.01kg*
Repeatability	±1g			±2g			±5g		
Linearity	±2g			±5g			±10g		
Span Drift	20ppm/°C typ. (5°C ~ 35°C)								
Display	7-Segment liquid crystal display, character height 18.6mm with back lighting + 60 segments Analog Sweep Display with back lighting								
Display Update	20 Times per Second								
Power Source	AC Mains (100V - 240V) or Sealed Lead Acid battery (option) Approximately 80 hours with no back lighting								
Ambient Conditions	-10°C ~ 40°C, Less than 85%R.H. (Non-condensing)								
Weighing Pan Size	250mm x 250mm						380mm x 300mm		
Dimension (W x D x H)	250mm x 414mm x 496mm						380mm x 464mm x 496mm		
Weight	8.1kg						14.9kg		

## OPTIONS

- HC-02i Sealed Lead Acid rechargeable battery (6V 4Ah)
- OP-03i RS232C with comparator relay output
- OP-04i RS422/485 with comparator relay output

## DIMENSIONS

### FS-30Ki

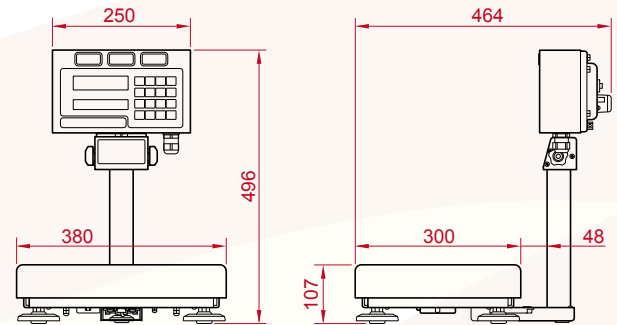

### FS-6Ki / FS-15Ki

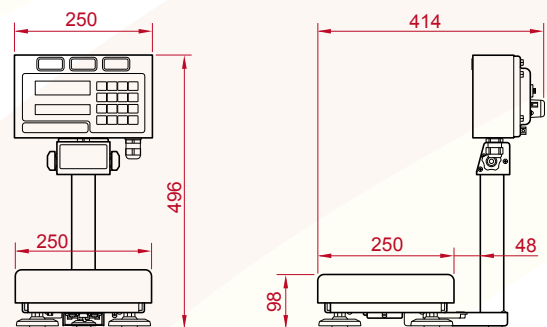

FS-6Ki with 250mm x 250mm Weighing Pan

Accuweigh Pty Ltd

WESTERN AUSTRALIA (HEAD OFFICE):  
PHONE: (08) 9259 5535

SOUTH AUSTRALIA OFFICE:  
PHONE: (08) 8447 5011

NEW SOUTH WALES (SYDNEY) OFFICE:  
PHONE: (02) 9728 4877



[www.accuweigh.com.au](http://www.accuweigh.com.au)

VICTORIA OFFICE:  
PHONE: (03) 9548 5554

NEW SOUTH WALES (NEWCASTLE) OFFICE:  
PHONE: (02) 4966 8900

QUEENSLAND OFFICE:  
PHONE: (07) 3265 5520